

T H E R M O M E T R I C S  
A C O M M I T M E N T T O E X C E L L E N C E

# HVAC Refrigerant Temperature Sensor GE-1920 for Automotive Applications



The refrigeration temperature sensor measures the refrigerant temperature both at the high pressure side and at the low pressure side of the line. The control module uses this information to maximize the performance of the HVAC system.

## Applications

- High pressure line temperature of the condenser and receiver/drier unit side
- Low pressure refrigeration line temperature measurement of the evaporator side
- Battery coolant temperature

## Features

- High accuracy and long term stability
- Fast response time
- Integral connector
- Existing field proven design
- Alternate RvT curves available
- 100°C Max operating temperature
- Plated steel body
- Other resistance and beta values available



**Amphenol**  
Advanced Sensors

# GE-1920 Specifications

**Operating Temperature Range**  
-40°C to 100°C (-40°F to 212°F)

**Storage Temperature Range**  
-40°C to 125°C (-40°F to 257°F)

**R @ 25°C (77°F)**  
2828Ω

**Response Time**  
<14 seconds

**Housing Material**  
Plated Steel

**Weight**  
~13.8 grams

**Connector**  
Packard Electric Micro-Pack

**Mating Connector**  
P/N 1209 2438

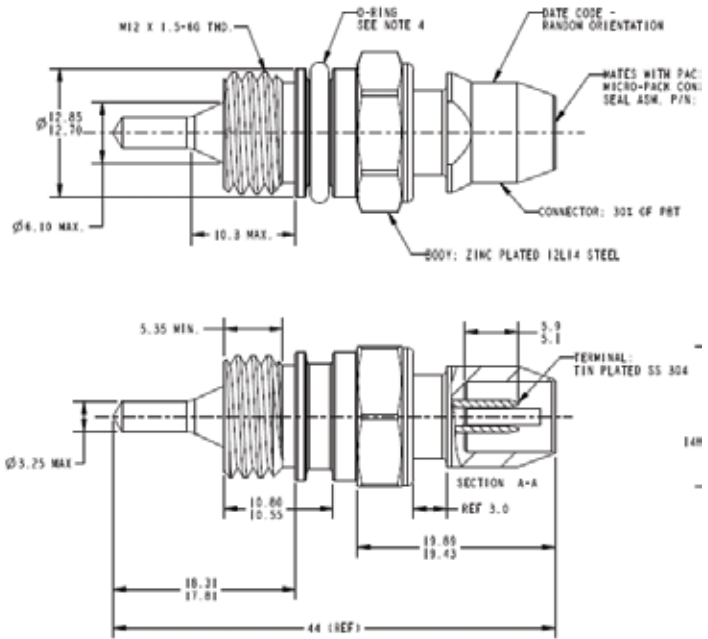

GE-1920 Dimensions

RvT Table			
Temp °C (°F)	RES. K OHMS		
	Min. (Ω)	Nom. (Ω)	Max (Ω)
-40 (-40°)	90.688	94.331	98.105
-20 (-4°)	26.565	27.377	28.209
0 (32°)	9.030	9.231	9.434
25 (77°)	2.791	2.828	2.865
60 (140°)	0.687	0.703	0.720
100 (212°)	0.186	0.192	0.198

**Amphenol**  
Advanced Sensors

[www.amphenol-sensors.com](http://www.amphenol-sensors.com)