

- 3V to 5.5V Input Range
- Accurate 350mA or 900mA Output Current
- High Efficiency
- Small 10-Pin MSOP Package
- 1.2MHz Switching Frequency Enables Small Components
- Integrated Design with Minimal Components.
- Use 4 cell alkaline, NiCad, NiMH, or 1 cell Lithium Ion Battery or 3.3V or 5V Logic supply

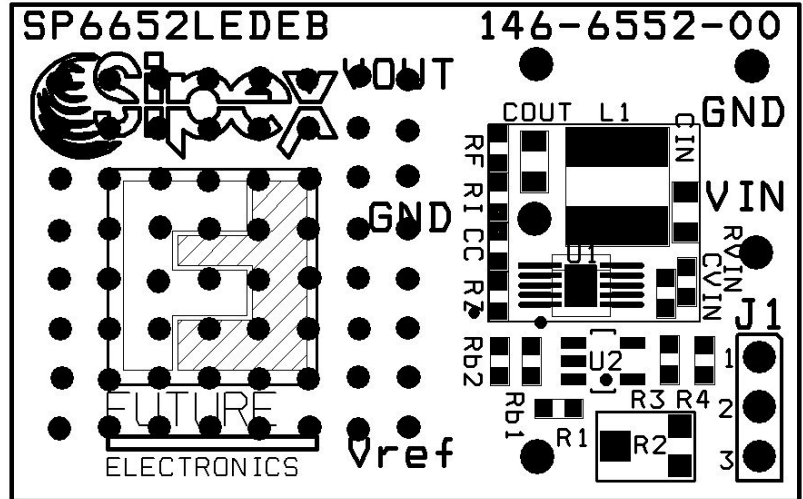

### DESCRIPTION AND BOARD SCHEMATIC

The **SP6652LED Evaluation Board** is a compact circuit that was built on SP6652 and can provide a stable drive current for a 1W or 3W Luxeon type light source. The SP6652 is an integrated synchronous buck regulator configured to provide constant output current for this application. The evaluation board is a completely assembled and tested surface mount board which provides easy probe access points to all SP6652 inputs and outputs so that the user can quickly connect and measure electrical characteristics and waveforms.

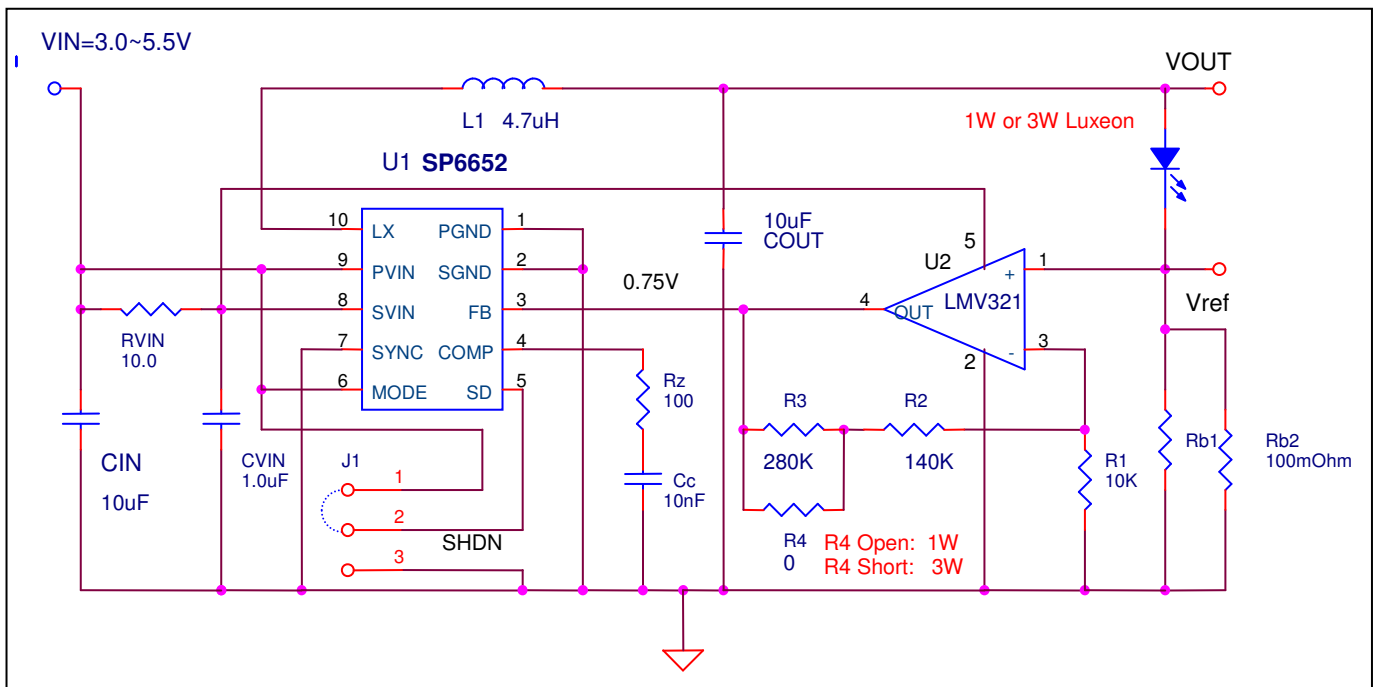

## USING THE EVALUATION BOARD

### 1) Powering Up the SP6652LED Circuit

The SP6652LED Evaluation Board can be powered from 4 cell alkaline, NiCad, NiMH, or 1 cell Lithium Ion Battery or 3.3V or 5V Logic supply. Connect with short leads directly to the “VIN” and “GND” posts. Plug the 1W Luxeon I or 3W Luxeon III between the “VOUT” and “Vref” posts.

### 2) Using the J1 Jumper for ON/OFF Control

When the hat is put on 1 & 2 position, the SHDN pin is connected to Vin. When the hat is put on 2 & 3 position, the SHDN pin is tied to ground and the part will be in shutdown mode.

### 3) Select from 1W or 3W Application

The board was set up for 1W application as default. In this application, R4 was open. When the customer need to use this board to drive Luxeon III, short R4 by using a 0 Ohm resistor.

## POWER SUPPLY DATA

For the standard evaluation board, the following chart shows the efficiency data for different applications.

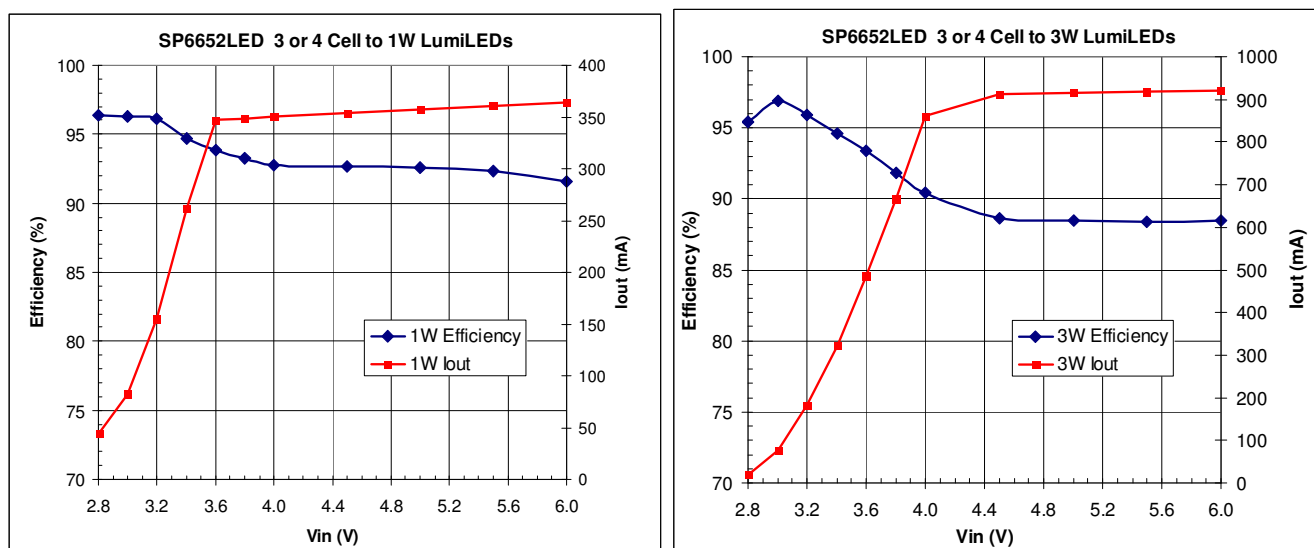

Fig. 1 Efficiency data of the SP6652LED evaluation board

# EVALUATION BOARD LAYOUT

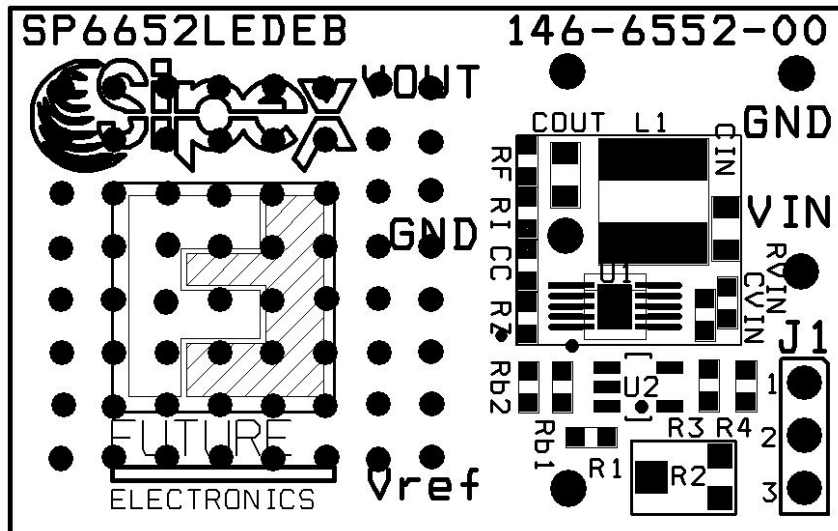

FIGURE 1: SP6652LEDEB COMPONENT PLACEMENT

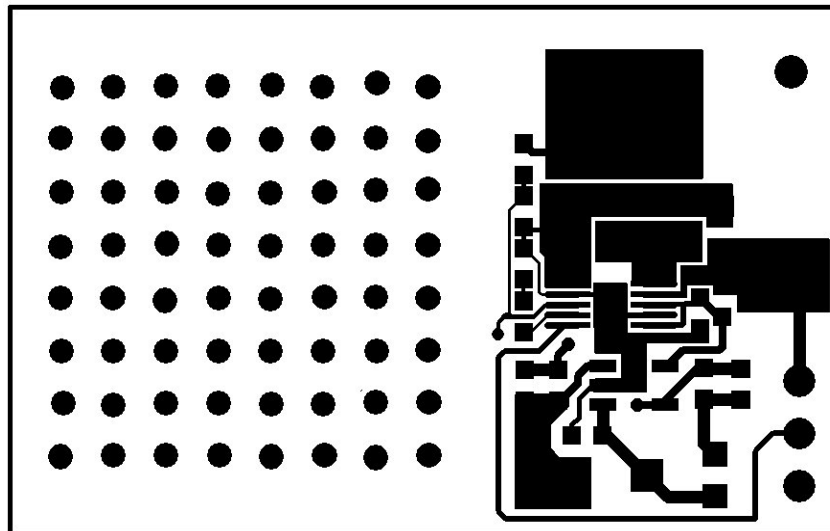

FIGURE 2: SP6652LEDEB PC LAYOUT TOP SIDE

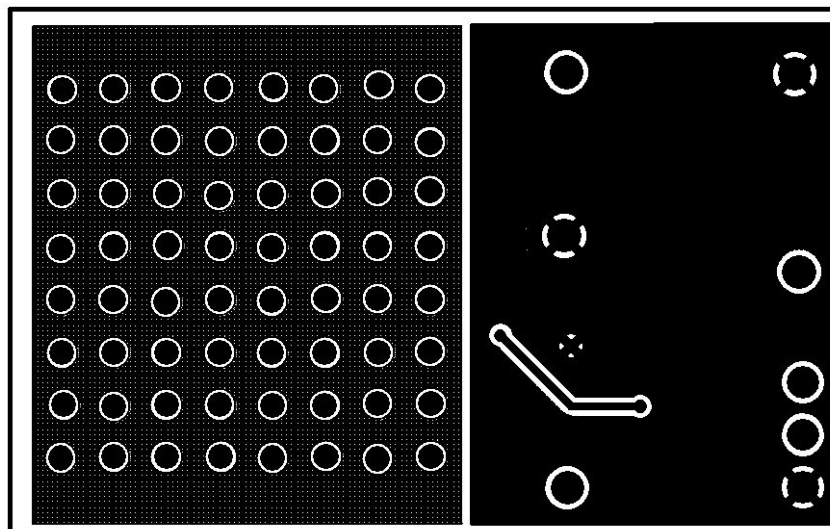

FIGURE 3: SP6652LEDEB PC LAYOUT BOTTOM SIDE

**TABLE1: SP6652LEDEB LIST OF MATERIALS**

SP6652LEDEB List of Materials						
Ref. Des.	Qty.	Manufacturer	Part Number	Layout Size	Component	Vendor
				LxWxH		
U1	1	Sipex Corp.	SP6652	MSOP-10	High Efficiency Current Mode Buck Regulator	Sipex 978-667-8700
U2	1	National Semi	LMV321M5	SOT23-5	Rail-to-Rail Output Operational Amplifiers	National Semi
C1N, COUT	2	TDK Corp	C2012X5R0J106M	0805	10uF/6.3V/X5R/ Ceramic	TDK 847-803-6100
CVIN	1	TDK Corp	C1608X5R1A105K	0805	1uF/10V/X5R/ Ceramic	TDK 847-803-6100
Cc	1	TDK Corp	C1608X7R1H103K	0805	10nF/50V/X7R/ Ceramic	TDK 847-803-6100
L1	1	Würth Elektronik	744042004	4.8x4.8x1.8mm	4.7uH, 1.7A, 0.07ohm, SM Inductor	www.we-online.com
D	1	LumiLEDs	Luxeon I and III		Open	LumiLEDs
Rb1	1	Vishay	CRCW0603R047F	0603	0.047 Ohm 1/16W 1% 0603 SM	www.vishay.com
Rb2	NU					
RVIN	1	Panasonic		0603	10 Ohm 1/16W 1% 0603 SM	800-Digi-Key
Rz	1	Panasonic		0603	100 Ohm 1/16W 1% 0603 SM	800-Digi-Key
R1	1	Panasonic		0603	10K Ohm 1/16W 1% 0603 SM	800-Digi-Key
R2	1	Panasonic		0603	140K Ohm 1/16W 1% 0603 SM	800-Digi-Key
R3	1	Panasonic		0603	280K Ohm 1/16W 1% 0603 SM	800-Digi-Key
R4	1	Panasonic		0603	Open	800-Digi-Key
RI, RF	2	Panasonic		0603	Open	800-Digi-Key
J1	1				3-Pin Jumper	800-Digi-Key

**ORDERING INFORMATION**

Model	Temperature Range	Package Type
SP6652LEDEB.....	-40°C to +85°C.....	SP6652LED Evaluation Board
SP6652EU.....	-40°C to +85°C.....	10-pin μSOIC