

THIS DRAWING IS UNPUBLISHED. RELEASED FOR PUBLICATION . 19

© COPYRIGHT 19 BY AMP INCORPORATED, HARRISBURG, PA. ALL INTERNATIONAL RIGHTS RESERVED. AMP PRODUCTS MAY BE COVERED BY U.S. AND FOREIGN PATENTS AND/OR PATENTS PENDING.

REVISIONS				
ZONE	LTR	DESCRIPTION	DATE	APPROVED
(F)	A	RELEASED PER P.A.R.	7/26/81	SS/64

D
C
B
A

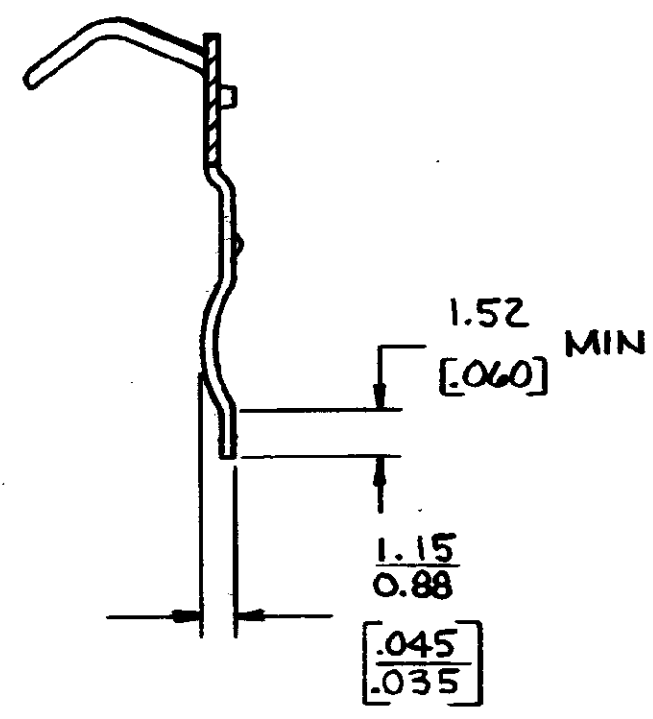
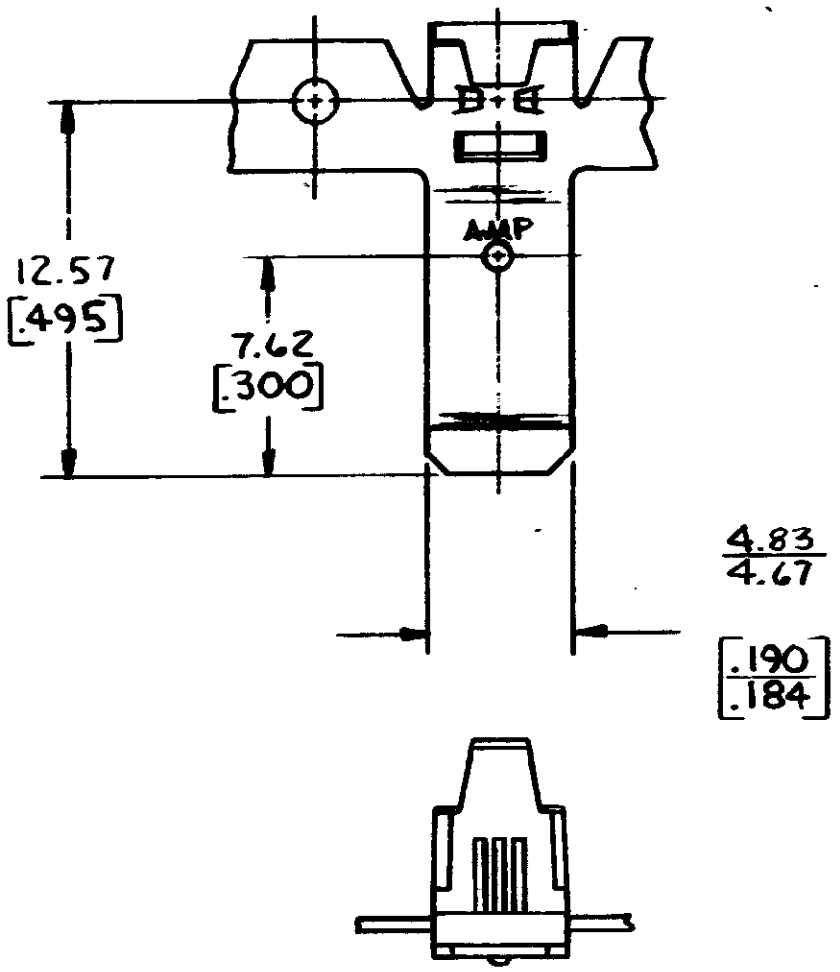

1. DIMS. IN BRACKETS ARE IN INCHES
2. CONTINUOUS STRIP ON REELS.

METRIC

UNLESS OTHERWISE SPECIFIED DIMENSIONS ARE IN INCHES MM		CONTRACT NO		0.5-2.0 mm ² [*20-*14]		63183-1	
TOLERANCES ON:		DR <i>J. Schaffner</i> 11/18/81		WIRE RANGE		PART NO	
DECIMALS ±0.38 [05]		CHK <i>G. Yetter</i> 11/20/81		AMP		AMP INCORPORATED Harrisburg, Pa.	
ANGLES ±		APPD <i>Rohweck</i> 11-20-81		NAME BRUSH CONTACT TAB-LOK (LEFT-HAND)			
MATERIAL 0.46 [018] PHOS BRONZE		APPD <i>W. Frantzen</i> 11/23/81		SIZE B		FSCM NO 00779	
FINISH NONE		DSGN APPD		DRAWING NO 63183		SHEET	
		OTHER APPD		SCALE			