

NOTE 1. PER TRAY:100 PIECES.
 2. REFER TO THE DF59 SERIES MATING/UNMATING OPERATION INSTRUCTION MANUAL(ETAD-H0496) FOR THE OPERATING OF THE PRODUCT.
 3. UL(FILE NO. E52653).
 C-UL(FILE NO. E52653) APPROVED PRODUCT.



1		PBT	UL94V-0 , NATURAL(WHITE)	3		PS	CLEAR
2		BRASS		2		BRASS	CONTACT AREA : GOLD PLATING 0.2µm MIN UNDER PLATING : NICKEL PLATING 0.5µm MIN
NO.	MATERIAL	FINISH , REMARKS		NO.	MATERIAL	FINISH , REMARKS	
UNITS	mm	SCALE	5 : 1	COUNT	1	DESCRIPTION OF REVISIONS	DIS-H-00000436
DESIGNED		TS. KUMAZAWA		CHECKED		TS. FUKUSHIMA	
DATE		15. 05. 15		APPROVED		KI. AKIYAMA 10. 10. 20	
DRAWING NO.		EDC3-332594-01		CHECKED		OM. MIYAMOTO 10. 10. 20	
PART NO.		DF59-2P-2SP(50)		DESIGNED		KT. ISHII 10. 10. 20	
CODE NO.		CL667-0017-0-50		DRAWN		KT. ISHII 10. 10. 20	
						1/2	

Operation Procedures for Crimp Socket

【 Mating 】

1. By positioning the convexity of the short circuit pin sides to the receptacle concavity, align the centers of the short circuit pin and the receptacle in pitch direction.

2. Press down at the center surface of short circuit pin.
 Note>Press down until the short circuit pin touches to the receptacle.

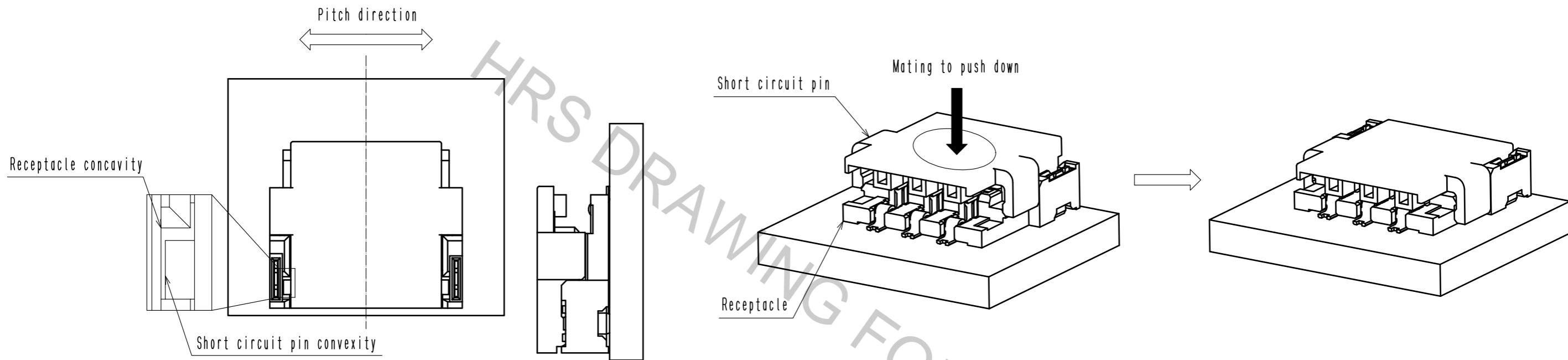

【 Unmating 】

1. Hook the lever with finger and lift up to the upper direction for unlock.

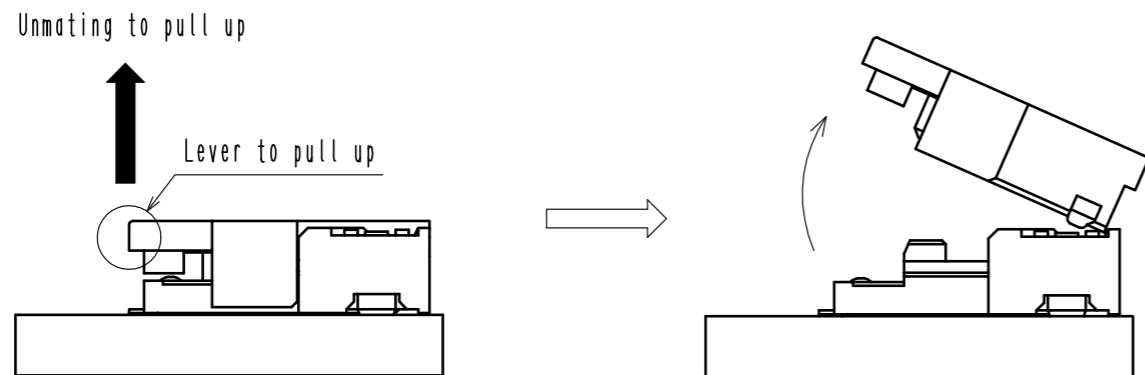

HRS	図番:	EDC3-332594-01	3/2
	製品名:	DF59-2P-2SP(50)	
	製品コード:	CL667-0017-0-50	